

WL70

Articulated Wheel Loaders



**WACKER
NEUSON**
all it takes!



The powerhouse

Thanks to the latest engine technology pursuant to the latest exhaust emission standard, the WL70 offers an extremely efficient, but also powerful engine that makes the wheel loader a powerhouse in action. This is being supported by a very robust, powerful load-arm design, which makes a quick and efficient materials handling possible. All electrical functions of attachment tools can optionally be operated by joystick. This increases efficiency and allows faster workflows.

- Powerful Perkins engine with 55.4 kW
- 3.5 inch color display with many functions and clear control lights
- Optional on-roof climate control for more operator comfort
- Optimized use of attachment tools by oil level regulation, high flow option and continuous function for the 3rd and 4th control circuits

WL70 Technical specifications

Engine / Motor

Engine / Motor manufacturer	Perkins
Engine / Motor type	854E-E34TAWF
Cylinder	4
Engine performance	55.4 kW
at rpm (max.)	2,200 rpm
Displacement	3,400 cm ³
Coolant type	water/water charge air

Electrical system

Operating voltage	12 V
Battery	95 Ah
Alternator	120 A

Weights

Operating weight	7,140 kg
Tipping load with bucket - machine straight	4,762 kg
Tipping load with bucket - machine at angle	3,926 kg
Tipping load with pallet fork - machine straight	4,254 kg
Tipping load with pallet fork - machine at angle	3,559 kg

Vehicle data

Bucket capacity (standard bucket)	1.1 m ³
Traction drive	Hydrostatic via universal joint shaft
Axles	PA1422
Drivers cab	Cabin
Speed	0-20 km/h
Speed (optional)	0-30 km/h
Speed Level	2
Standard tires	405/70 R 18 EM ETO

Hydraulic system

Driving hydraulics - operating pressure	445 bar
Operating hydraulics - operating pressure	210 bar
Operating hydraulics - discharge capacity	100 l/min
Operating hydraulics - discharge capacity (optional up to)	150 l/min

Filling capacities

Fuel tank capacity	105 l
Hydraulic oil tank	95 l

Sound level

Guaranteed sound power level LwA	103 dB(A)
Specified sound pressure level LpA	78 dB(A)

Standard bucket = digging bucket, 2,000 mm width
Tipping load calculation according to ISO 14397-EN474-3

WL70 Dimensions

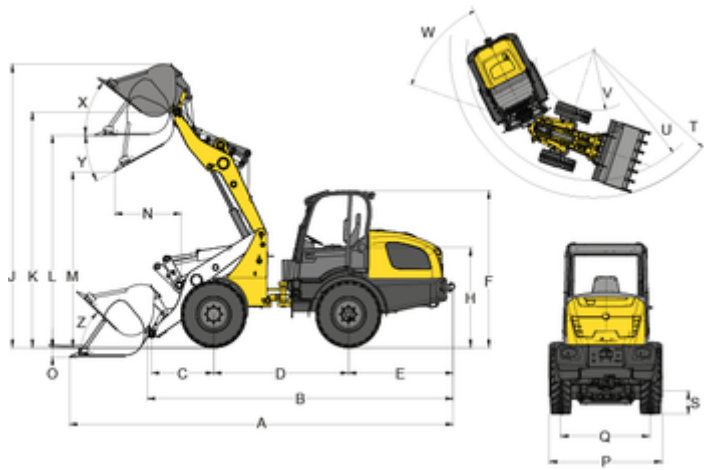

	Standard tires	405/70 R 18 EM ETO
A	Overall length	5,898 mm
B	Overall length without bucket	4,780 mm
C	Bucket pivot point to axle center	991 mm
D	Wheelbase	2,150 mm
E	Rear overhang	1,676 mm
F	Height With cabin	2,693 mm
H	Seat height	1,609 mm
J	Total operating height	4,536 mm
K	Stroke height max. - bucket pivot point	3,686 mm
L	Overhead loading height	3,375 mm
M	Dump height max.	2,840 mm
N	Range with M	799 mm
O	Scraping depth	73.5 mm
P	Overall width	1,829 mm
Q	Track width	1,422 mm
S	Ground clearance	375 mm
T	Radius maximum	4,341 mm
U	Radius at outer edge	3,686 mm
V	Inside turning radius	1,666 mm
W	Articulation angle	42 °
X	Bucket rollback at max. stroke height	33 °
Y	Dump angle Maximum	33 °
Z	Bucket rollback at ground level	39 °

All values with standard bucket: Digging bucket 2,000 mm, 1.1 m³ and standard tires: 405/70 R 18 EM ETO

Please note: that product availability can vary from country to country. It is possible that information / products may not be available in your country. More detailed information on engine power can be found in the operator's manual; the stated power may vary due to specific operating conditions. Subject to alterations and errors excepted. Applicable also to illustrations.
Copyright © 2020 Wacker Neuson SE.